

UNITED STATES DISTRICT COURT  
MIDDLE DISTRICT OF FLORIDA  
ORLANDO DIVISION

K.Mizra LLC,

Plaintiff,

v.

Toshiba Corporation; Toshiba TEC Corporation; Toshiba America Business Solutions, Inc.; American Business Systems, Inc.; Clearview Business Solutions LLC; and Copy Concepts Inc.,

Defendants.

Case No. 6:21-cv-1293-\_\_\_\_\_

**COMPLAINT FOR PATENT  
INFRINGEMENT AND DEMAND FOR A  
JURY TRIAL**

Plaintiff K.Mizra LLC (“Plaintiff” or “K.Mizra”), for its Complaint with Jury Demand for Patent Infringement against Defendants Toshiba Corporation; Toshiba TEC Corporation; Toshiba America Business Solutions, Inc.; American Business Systems, Inc.; Clearview Business Solutions LLC; and Copy Concepts Inc. (“Defendants”), alleging, based on its own knowledge as to itself and its own actions and based on information and belief as to all other matters, states as follows:

**I. INTRODUCTION**

**A. Sharp and Its Innovations**

1. Sharp Corporation (“Sharp”) is a Japanese multinational company that has for more than a century conceived, designed, manufactured and sold, first in Japan and then worldwide, various innovative products. Indeed, the company was founded in 1912 in Tokyo and takes its name from one of its founder’s first inventions, the Ever-

Sharp mechanical pencil. Sharp currently employs more than 50,000 people worldwide and has been inventing the future in numerous existing and emerging product categories for decades.

2. For more than sixty years now, Sharp has been heavily involved in the electronics products business, developing the first Japanese-produced televisions in 1953 and its Mobile Communications Division created the world's first camera phone in 2000. Sharp also was then investing heavily in its document product and solutions division, earning high praise and prestigious awards from various industry publications and insiders for innovations in printer, copier, and facsimile technologies it was developing and introducing to the market. Indeed, many of these innovations changed these product categories forever and helped to establish multifunction printers, i.e., all-in-one copier, printing, faxing and scanning devices ("MFPs"), as a mainstay of the modern office. These products take many forms, with one such Sharp device being shown below:



3. Sharp's MFPs were precision engineered to make device setup easier and faster than previously available and to provide easy-to-use, efficient and effective multi-level document production and assembly functionality to the modern and typical office worker. Sharp's integrated product design and engineering approach to developing these state-of-the-art MFP's resulted in providing office workers increased workflow efficiency, exceptional image quality and an industry standard ease of product operation, control, management, and maintenance, helping to take its customer's business to the next level of productivity and performance.

4. Given its culture of innovation and recognizing that its industry changing concepts often were emulated by “Johnny-come-lately” competitors, Sharp took pains to document and protect its various MFP-focused inventions. These took the form of, among other things, filing and prosecuting to issuance many patents covering various aspects of the technologies it had developed and incorporated over time into its various MFP products. These patents were issued in many countries, including the United States, Germany and Japan. As is too often the case, though, these protections were not self-policing in the MFP industry, with many of Sharp’s competitors having taken its patented technologies for themselves and incorporating them into their commercial MFP offerings, but without providing Sharp the economic credit deserved for its many, many efforts and advancements. This case concerns just such a situation.

**B. K.Mizra and This Action**

5. K.Mizra is a patent licensing company run by experienced management. The company focuses on high value, high quality patents with a global reach and owns patent portfolios originating with a wide array of inventors, including portfolios developed by well-known multinationals such as IBM, Panasonic and ZTE and from research institutes such as National Chiao Tung University and Nederlandse Organisatie voor Toegepast Natuurwetenschappelijk Onderzoek (Netherlands Organization for Applied Scientific Research). By focusing on high quality patents, K.Mizra provides a secondary market for inventors to recoup their research and development investments and to continue their innovations. K.Mizra offers licenses

to its patents on reasonable terms and in this way plays a part in the development of the technologies that improve our lives.

6. Sharp recently transferred its MFP-focused patents to K.Mizra, which now brings this action to enforce these valid and subsisting United States patent rights. K.Mizra is the owner by assignment of all rights, title, and interests in and to the patents discussed below (“the Asserted Patents”).

## II. PARTIES

7. Plaintiff is a limited liability company organized and existing under the laws of the State of Delaware and maintains a business address at 777 Brickell Avenue, #500-96031, Miami, Florida 33131.

8. Defendant Toshiba Corporation is a company organized and existing under the laws of Japan having a principal place of business at 1-1, Shibaura 1-chome, Minato-ku, Tokyo 105-8001, Japan.

9. Defendant Toshiba TEC Corporation is a company organized and existing under the laws of Japan having a principal place of business at Gate City Ohsaki West Tower, 1-11-1, Osaki, Shinagawa-ku, Tokyo 141-8562, Japan. On information and belief, Toshiba Corporation owns at least 50% of the stock of Toshiba TEC Corporation.

10. Defendant Toshiba America Business Solutions, Inc. is a company organized and existing under the laws of the State of California having a principal place of business at 25530 Commercentre Drive, Lake Forest, California 92630. Toshiba America Business Solutions, Inc. may be served via its registered agent, CT

Corporation System, 1200 South Pine Island Road, Plantation, Florida 33324. On information and belief, Toshiba America Business Solutions, Inc. is a subsidiary of Toshiba TEC Corporation.

11. Defendants Toshiba Corporation, Toshiba TEC Corporation, and Toshiba America Business Solutions, Inc. (collectively “Toshiba”) have acted in concert with respect to the conduct complained of herein such that any action of one is attributable to all three.

12. Defendant American Business Systems, Inc. (“ABS”) is a company organized and existing under the laws of the State of Florida having a principal place of business at 9637 Hood Road, Jacksonville, Florida 32257-1127. ABS may be served via its registered agent, Phillip D. Klusmeier, 9637 Hood Road, Jacksonville, Florida 32257.

13. Defendant Clearview Business Solutions LLC (“Clearview”) is a limited liability company organized and existing under the laws of the State of Florida having a principal place of business at 5801 Benjamin Center Drive, Suite 110, Tampa, Florida 33634-5206. Clearview may be served via its registered agent, Murtha & Murtha LLC, 2236 Ashley Oaks Circle #101, Wesley Chapel, Florida 33544.

14. Defendant Copy Concepts Inc. (“Copy Concepts”) is a company organized and existing under the laws of the State of Florida having a principal place of business at 1901 Brantley Road, Units 9 & 10, Fort Myers, Florida 33907. Copy Concepts may be served via its registered agent, Ronald Hickox, 1901 Brantley Road, Units 9 & 10, Fort Myers, Florida 33907.

15. ABS, Clearview, and Copy Concepts are collectively referred to herein as “the Dealer Defendants.”

### **III. JURISDICTION AND VENUE**

16. This is an action for patent infringement under the patent laws of the United States, namely, 35 U.S.C. §§ 101 *et seq.*, 271, 281, and 284, among others. This Court has original subject matter jurisdiction over this dispute pursuant to 28 U.S.C. §§ 1331 and 1338(a).

17. This Court has personal jurisdiction over Toshiba for at least the following reasons: (1) Toshiba has imported, manufactured, used, offered for sale, and/or sold in Florida, and within this District, printer/copier/scanner products that infringe the Asserted Patents (defined collectively as the patents discussed below); (2) Toshiba maintains permanent offices in Florida and in this district operating as “Toshiba Business Solutions”; (3) Toshiba maintains sales representatives in Florida including the Dealer Defendants; (4) Toshiba is registered with the Florida Department of State to do business in Florida; (5) Toshiba has a registered agent in Florida, at CT Corporation System, 1200 South Pine Island Road, Plantation, Florida 33324; (6) upon information and belief, Toshiba has paid and continues to pay taxes in Florida; and (7) Toshiba has a website directed to customers in Florida from which customers can contact Toshiba to purchase printer/copier/scanner products that infringe the Asserted Patents at issue in this lawsuit.

18. This Court also has personal jurisdiction over Toshiba through Toshiba's regular, systematic, and continuous contacts in providing support and control over its dealers located in the Middle District of Florida.

19. This Court has personal jurisdiction over each of the Dealer Defendants because each of them is an entity formed under the laws of the State of Florida and has its principal place of business in Florida, and thus is a Florida resident.

20. Venue is proper in this judicial district pursuant to 28 U.S.C. § 1400(b) because (1) the Dealer Defendants each are deemed to reside in this district; and (2) Toshiba has committed acts of infringement in this district and has regular and established places of business in this district including at 5810 Breckenridge Parkway, Tampa, Florida 33610 and 2815 Directors Row Suite 900, Orlando, Florida. Toshiba's acts of infringement in this District include but are not limited to its importation, manufacture, use, offer for sale, and/or sale of printer/copier/scanner products that infringe the Asserted Patents.

21. Toshiba, through its website at <http://business.toshiba.com/dealers/>, advertises at least ten (10) Toshiba sales offices and dealers in this District, including but not limited to the Dealer Defendants.

#### **IV. FACTUAL ALLEGATIONS**

##### **A. The Asserted Patents**

##### **1. U.S. Patent 7,064,874**

22. On June 20, 2006, the USPTO duly and legally issued U.S. Patent No. 7,064,874 ("the '874 Patent") entitled "Both-Side Document Reading Apparatus and



Both-Side Document Reading Method” to Sharp. Sharp assigned the ’874 Patent to K.Mizra, and that Assignment is recorded beginning at Reel/Frame No. 054223/0499 of the USPTO Assignment database. A copy of the ’874 Patent is attached hereto as **Exhibit 1** and incorporated herein, in its entirety, by reference.

23. The ’874 Patent discloses a both-side reading apparatus used, for example, in scanners, copiers, printers, facsimiles or the like, and a both-side document reading method. In one aspect of the systems and methods disclosed in the patent, an amount of the illumination light applied to the surfaces of a document is held constant until the reading operation at both the main and back surfaces of the document has been completed. This allows both sides of a document to be read under constant reading conditions and prevents errors or artifacts that occur from variable illumination or opposing light sources. Claim 18 of the ’874 Patent addresses these concepts and states:

An image forming apparatus comprising a both-side document reading apparatus, the both-side document reading apparatus comprising:

a first reading portion, provided with a first light source, for reading one side surface of a document by emitting light toward the one side surface of the document by the first light source; and

a second reading portion, provided with a second light source, for reading another side surface of the document by emitting light toward the other side surface of the document by the second light source,

wherein the first and second reading portions are arranged so that a reading region of the one side surface by the first reading portion is arranged on an upstream side from a reading region of the other side surface by the second reading portion in a document transport direction, and

wherein the first light source is turned off after the document has passed through the reading region of the second reading portion.

24. Multiple Toshiba MFPs meet all limitations of Claim 18 of the '874 Patent. For example, Toshiba MFP model e-STUDIO5506AC is an image forming apparatus, *i.e.*, printer, that contains a both-side document reader capable of duplex scanning:

## e-STUDIO5506AC

55 PPM, Color / 65 PPM, Mono  
3,520/6,020 Paper Capacity (Std./Max)  
**240 Duplex Scans Per Minute**  
Service Module Design  
Broad Media Range Support  
Available in U.S. and Latin America



### SCAN SPECIFICATIONS

|                        |  |
|------------------------|--|
| <b>Scan Speed</b>      | <b>DSDF Scan</b> Up to 240 IPM Duplex, 120 IPM Simplex (Monochrome or Color) |
| <b>Scan Modes</b>      | Standard: Full Color, Auto Color, Monochrome, Grayscale                      |
| <b>Scan Resolution</b> | 600 dpi, 400 dpi, 300 dpi, 200 dpi, 150 dpi, 100 dpi                         |

25. The e-STUDIO5506AC printer contains a flatbed scanner that contains the claimed first reading portion and first light source. The scanner lamp of the e-STUDIO5506AC printer illuminates the downward-facing side of a document by emitting light onto that document that is read by a CCDM. The claimed second reading portion of the e-STUDIO5506AC is housed in the automated document feeder

(“ADF”). Within the ADF (*see* below), an ADF CCDM contains a second light source, a lamp, that emits light onto the other, upward-facing side of the document to read that surface.

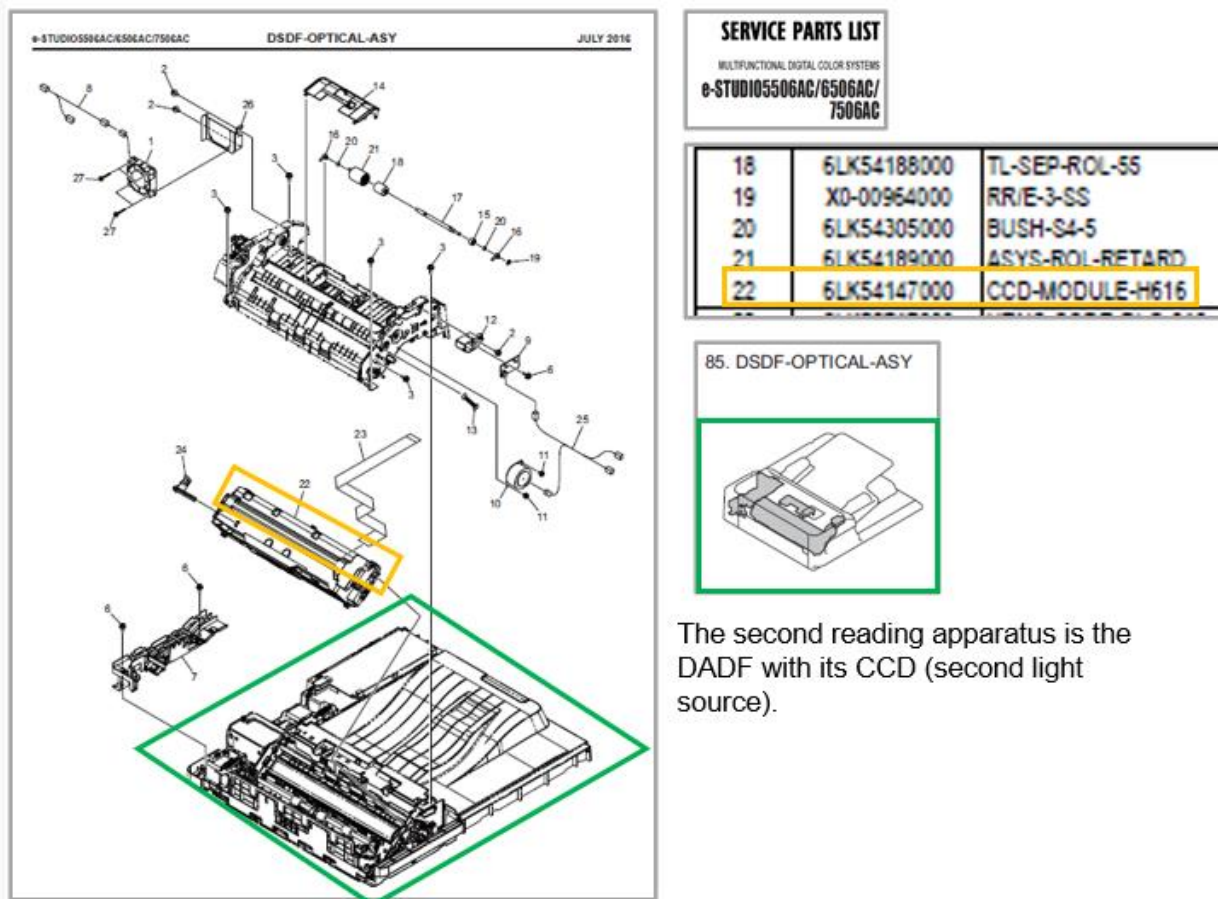

26. As shown below, the e-STUDIO5506AC printer is designed such that sheets of paper to be duplex scanned are placed in the ADF tray from which they are fed by rollers into the ADF. By design, during duplex scanning, the document is transported in a single direction by the rollers—from the ADF tray, the document page is moved past the surface of the flatbed scanner and then up into the ADF and past the ADF CCDM before being ejected into the ADF bin when scanning is complete. In this document page flow, the document is first scanned in a region above the flatbed

scanner, where the downward-facing side of the document is read. This first region is upstream of a separate region where the other, upward-facing side of the document is read.



27. Thus, the document passes downstream as it travels from the ADF tray, through the first and then second reading regions, and into the ADF bin, with each side scanned sequentially. After the scanning is complete, the scanner lamp of the e-STUDIO5506AC turns off automatically.

28. On information and belief, the e-SUDIO5506AC is representative of other Toshiba products that infringe or have infringed the '874 Patent, including without limitation the following Toshiba model numbers: e-Studio1057, e-Studio1058, e-Studio1207, e-Studio1208, e-Studio2000AC, e-Studio2008A, e-Studio2018A, e-Studio2500AC, e-Studio2505AC, e-Studio2508A, e-Studio2515AC, e-Studio2518A, e-Studio3005AC, e-Studio3005ACG, e-Studio3008A, e-Studio3008AG, e-Studio3015AC, e-Studio3015ACG, e-Studio3018A, e-Studio3018AG, e-

Studio330AC, e-Studio3505AC, e-Studio3508A, e-Studio3515AC, e-Studio3518A, e-Studio400AC, e-Studio409S, e-Studio4505AC, e-Studio4508A, e-Studio4508LP, e-Studio4515AC, e-Studio4518A, e-Studio478S, e-Studio5005AC, e-Studio5005ACG, e-Studio5008A, e-Studio5008AG, e-Studio5015AC, e-Studio5015ACG, e-Studio5018A, e-Studio5018AG, e-Studio5506ACG, e-Studio5508A, e-Studio5516AC, e-Studio5516ACTG, e-Studio5518A, e-Studio6506AC, e-Studio6508A, e-Studio6508AG, e-Studio6516AC, e-Studio6518A, e-Studio6518AG, e-Studio7506AC, e-Studio7506ACG, e-Studio7508A, e-Studio7516AC, e-Studio7516ACTG, e-Studio7518A, e-Studio8508A, e-Studio8508AG, e-Studio8518A, e-Studio8518AG, e-Studio907 and e-Studio908 (collectively with the e-STUDIO5506AC, “the Toshiba ’874 Patent Accused Products”).

**2. U.S. Patent 7,570,400**

29. On August 4, 2009, the USPTO duly and legally issued U.S. Patent No. 7,570,400 (“the ’400 Patent”) entitled “Document Reading Device” to Sharp. Sharp assigned the ’400 Patent to K.Mizra and that Assignment is recorded beginning at Reel/Frame No. 054223/0499 of the USPTO Assignment database. A copy of the ’400 Patent is attached hereto as **Exhibit 3** and incorporated herein, in its entirety, by reference.

30. The ’400 Patent claims inventions over automatic document feeders included with printer devices and is directed to an arrangement where there is a movable member on the bottom side of the document feeder that pivots perpendicular to the paper transport path and covers a portion of the paper transport path. The

movable member allows access to the transport path to remove jammed paper. The bottom side of the feeder also contains a flexible sheet to hold paper onto the copying surface. This flexible sheet is anchored away from the pivot point of the movable member to avoid creasing the flexible sheet over time. Claim 1 of the '400 Patent is directed to at least some of these concepts and states:

A document reading device configured to read an image of an original document placed on a document platen, comprising:

a document tray for an original document to be stacked thereon;

an output tray for receiving the original document that is output after an image thereof is read;

a document transport path on which the original document is transported, the original transport path leading from the document tray through an image reading area to the output tray;

a movable member that serves as part of a bottom surface of the document reading device, the movable member being supported pivotably around a pivot axis that is perpendicular to a document transport direction on the document transport path, and the movable member having a free end and a pivotal end; and

a document holder that includes a flexible sheet, the document holder being positioned so as to extend over the whole length and breadth of the document platen,

wherein the movable member is pivotable from a position to cover a portion of the document transport path to a position to expose the portion toward the document platen, and

wherein the document holder is fixed at portions other than a portion that is positioned immediately below the pivot axis, to the bottom surface of the document reading device.

31. Multiple Toshiba MFPs meet all limitations of the Claim 1 of the '400 patent. For example, the Toshiba MFP model e-STUDIO5518A is a document

reading device, i.e., scanner, configured to read images of documents. The e-STUDIO5518A contains a flatbed scanner with the claimed document platen, i.e. flatbed scanner, where an original document can be placed. The e-STUDIO5518A also contains an ADF with a tray where original documents can be stacked to be scanned, as shown below:

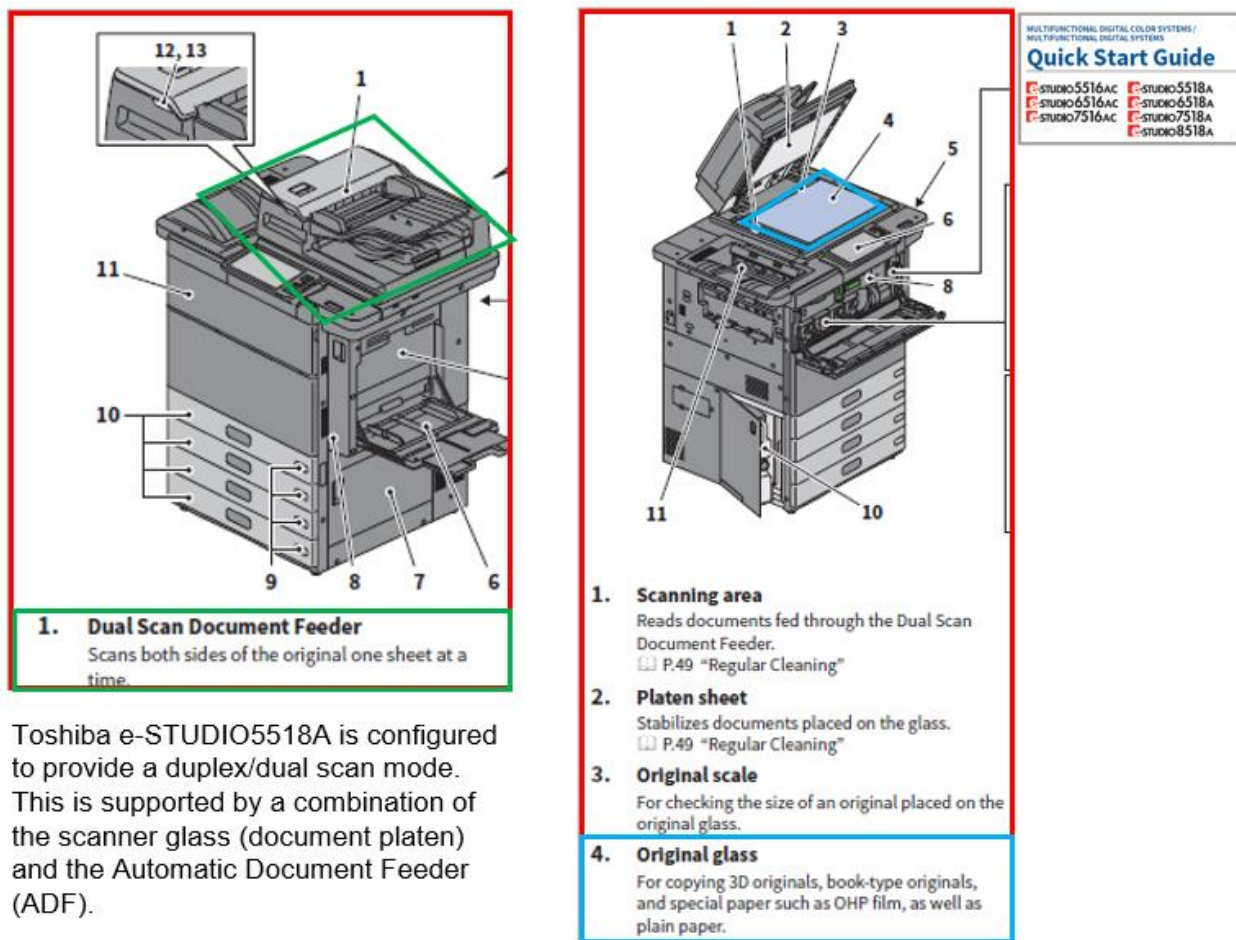

Toshiba e-STUDIO5518A is configured to provide a duplex/dual scan mode. This is supported by a combination of the scanner glass (document platen) and the Automatic Document Feeder (ADF).

32. The ADF also has an ADF bin that receives the original documents output after scanning. The e-STUDIO5518A pulls documents to be scanned along a set path by a series of rollers from the ADF tray, through an area where they are read

by the ADF CCDM and output to the ADF bin, all as disclosed and claimed by the '400 Patent.

33. The ADF of the e-STUDIO5518A printer also contains a movable ADF bottom door at its base, opposite the flatbed scanner platen. That door is attached pivotably to the ADF by a hinge along its side next to the ADF bin and perpendicular to the flow of documents. The other end of the ADF bottom door moves freely and can swing open exposing the usually hidden rollers located along the document transport path and that flow over the ADF bottom door.

34. On the bottom of the e-STUDIO5518A's ADF, there is a flexible white sheet of material that acts to hold documents in place on the flatbed scanner and acts as a neutral background for document reading. The document-holding sheet is attached to the flat bottom surface of the ADF and the base of the ADF bottom door at a number of fixed points. These fixed points are not immediately below the pivot axis of the ADF bottom door as claimed.



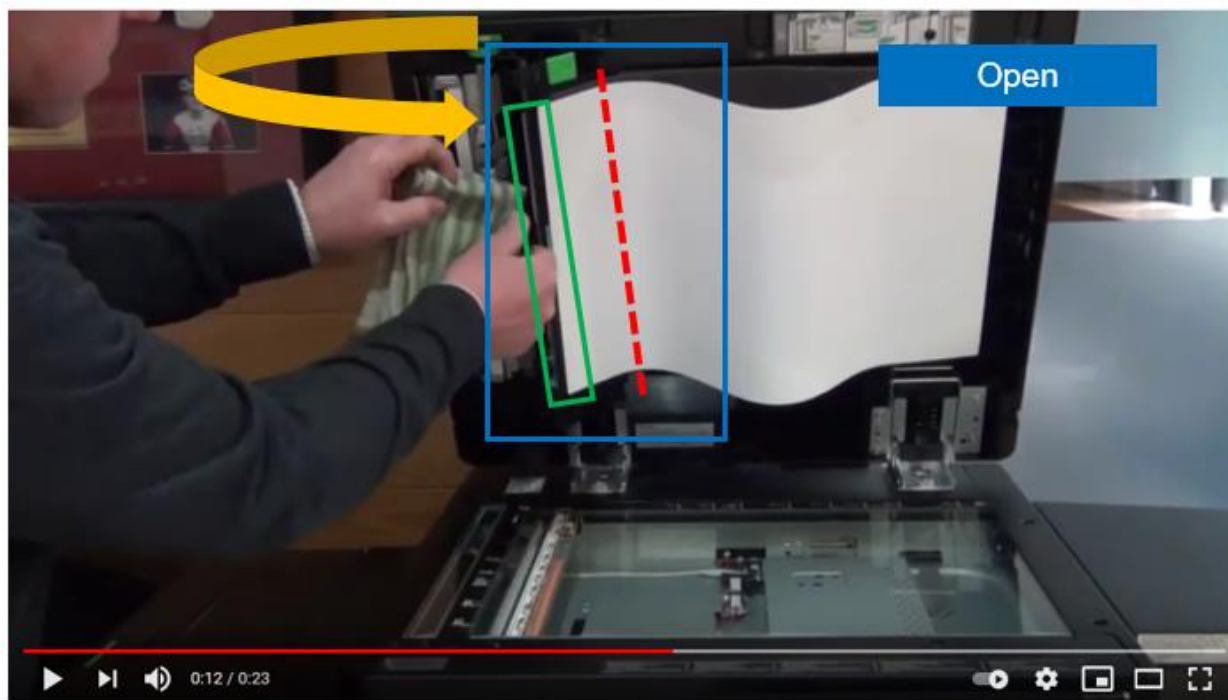
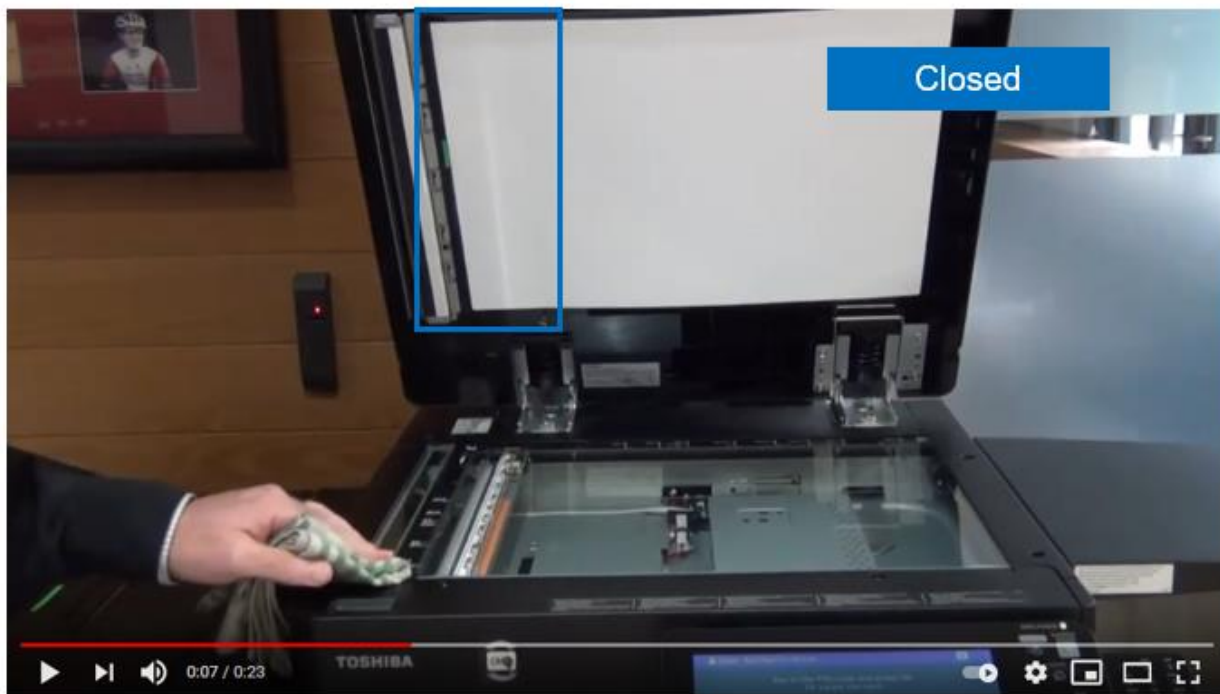

35. On information and belief the e-STUDIO5518A is representative of other Toshiba products that infringe or having infringed the '400 Patent, including without limitation the following model numbers: e-Studio1057, e-Studio1058, e-Studio1207,

e-Studio1208, e-Studio2000AC, e-Studio2008A, e-Studio2018A, e-Studio2500AC, e-Studio2505AC, e-Studio2508A, e-Studio2515AC, e-Studio2518A, e-Studio3005AC, e-Studio3005ACG, e-Studio3008A, e-Studio3008AG, e-Studio3015AC, e-Studio3015ACG, e-Studio3018A, e-Studio3018AG, e-Studio3505AC, e-Studio3508A, e-Studio3515AC, e-Studio3518A, e-Studio4505AC, e-Studio4508A, e-Studio4515AC, e-Studio4518A, e-Studio5005AC, e-Studio5005ACG, e-Studio5008A, e-Studio5008AG, e-Studio5015AC, e-Studio5015ACG, e-Studio5018A, e-Studio5018AG, e-Studio5506AC, e-Studio5506ACG, e-Studio5508A, e-Studio5516AC, e-Studio5516ACTG, e-Studio6506AC, e-Studio6508A, e-Studio6508AG, e-Studio6516AC, e-Studio6518A, e-Studio6518AG, e-Studio7506AC, e-Studio7506ACG, e-Studio7508A, e-Studio7516AC, e-Studio7516ACTG, e-Studio7518A, e-Studio8508A, e-Studio8508AG, e-Studio8518A, e-Studio8518AG, e-Studio907 and e-Studio908 (collectively with the e-STUDIO5518A, “the Toshiba ’400 Patent Accused Products”).

### **3. U.S. Patent 7,852,504**

36. On December 14, 2010, the USPTO duly and legally issued U.S. Patent No. 7,852,504 (“the ’504 Patent”) entitled “Image Forming Device, Print Job Transmission Device, Data Management Device, Program, Storage Medium and Method for Supplying Print Sheet” to Sharp. Sharp assigned the ’504 Patent to K.Mizra and that Assignment is recorded beginning at Reel/Frame No. 054223/0499 of the USPTO Assignment database. A copy of the ’504 Patent is attached hereto as **Exhibit 5** and incorporated herein, in its entirety, by reference.

37. The '504 Patent is directed to printers and copiers with multiple paper sheet options. The '504 Patent discloses paper specification preference conditions and indicators and the selection of a paper tray in accordance with selected print condition priorities. Claim 1 of the '504 Patent is directed to at least some of these concepts and states:

An image forming device, comprising:

a transmission/reception section which functions as an interface to a network;

a control section for generating a tray selection signal in accordance with a print job inputted to the transmission/ reception section, said print job including a print condition indicative of a condition for printing; and

a sheet feeding tray section, having a plurality of sheet trays capable of storing sheets of different types therein, which supplies a sheet from one of the sheet trays that has been selected in accordance with the tray selection signal transmitted from the control section, wherein said control section includes:

an operation control section for extracting the print condition from the print job and for obtaining an order table, indicative of a priority based on the print condition that has been extracted, from setting information, indicative of a sheet type priority indicating a type of paper corresponding to the print condition, wherein the order table specifies one of the sheet trays; and

a tray selection section for generating the tray selection signal for selecting one of the sheet trays, in accordance with the order table transmitted from the operation control section.

38. Multiple Toshiba MFPs meet all limitations of Claim 1 of the '504 Patent. For example, the Toshiba MFP product model e-STUDIO907 is an image forming device capable of executing print jobs received over a network. The e-STUDIO907 has a series of internal or attached sheet trays that can feed paper of

various sizes and characteristics based on the settings of a print job received over a connected network. By using these trays, the e-STUDIO907 supports printing on multiple sheet types and sizes, as the following describes:

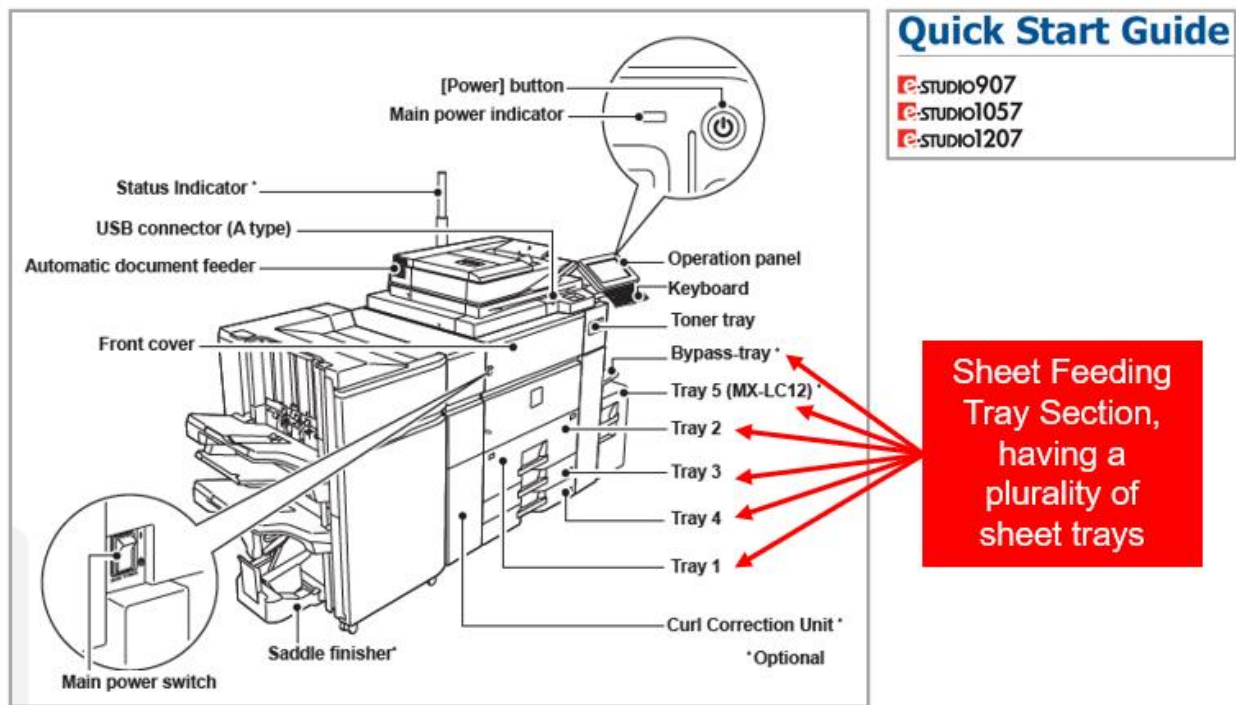

39. The specific sheet tray that is triggered to feed a sheet of paper for printing is based on the characteristics of an assigned print job. In general, the printer prioritizes the print settings received from a host device, then relies upon the Print Driver settings to accomplish desired printing functions. The e-STUDIO907 also contains print preferences within its own print settings, which can be configured by the user. These preferences form a hierarchical table of print preferences used to select the appropriate sheet based on the available sheets and the conditions extracted from the received print job. The e-STUDIO907's print table determines the prioritized sheet and sends a signal to the corresponding tray to feed the appropriate sheet paper for

printing. Upon receipt of the tray selection signal, the tray responsive to the paper specifications commences a sheet-feeding action. In this way, the e-STUDIO907 functions as claimed, as shown below:

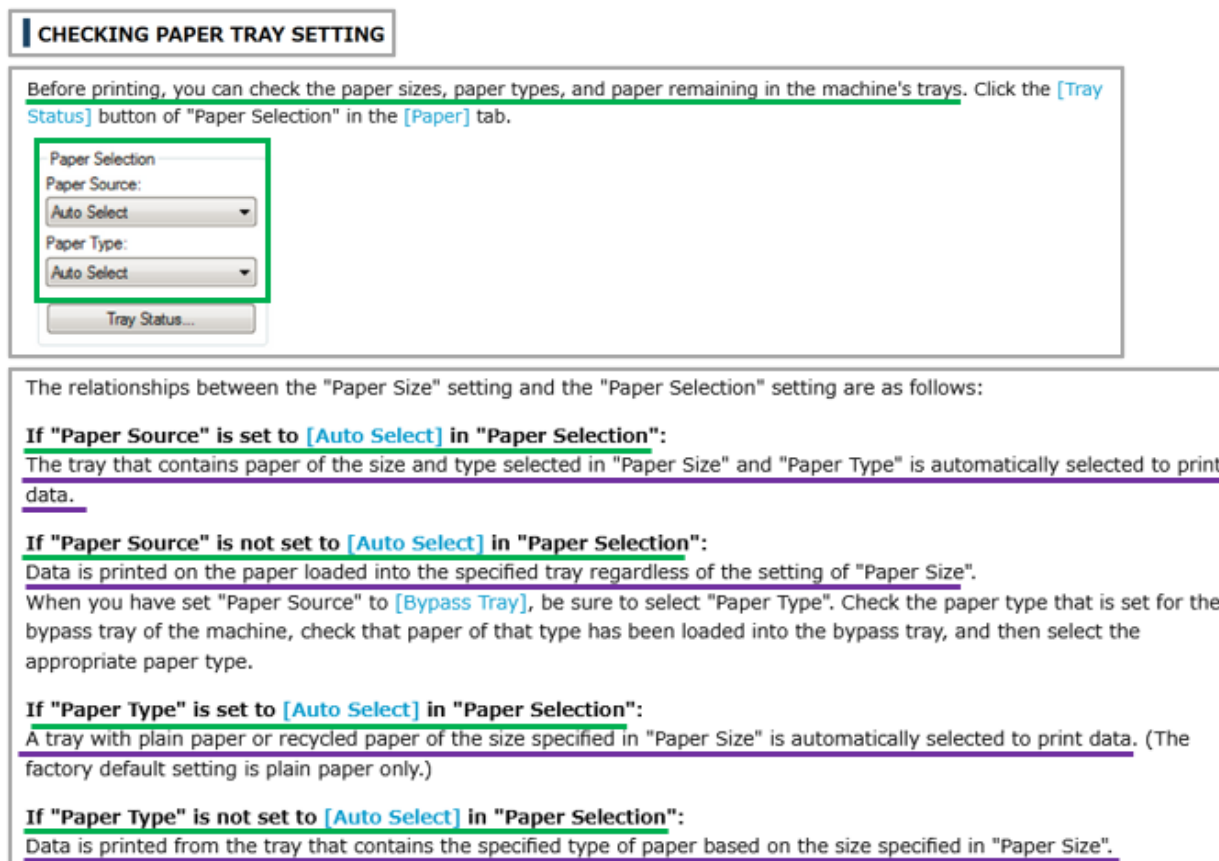

40. On information and belief, the e-STUDIO907 is representative of other Toshiba products that infringe or have infringed the '504 Patent, including without limitation the following model numbers: e-Studio1057, e-Studio1207 and e-Studio507 (collectively with the e-STUDIO907, "the Toshiba '504 Patent Accused Products").

#### 4. U.S. Patent 8,274,711

41. On September 25, 2012, the USPTO duly and legally issued U.S. Patent No. 8,274,711 ("the '711 Patent") entitled "Document Reading Apparatus Capable of

Sequentially Reading Documents Stacked on an Automatic Document Feeder and a Document Set on a Platen” to Sharp. Sharp assigned the ’711 Patent to K.Mizra and that Assignment is recorded beginning at Reel/Frame No. 054223/0499 of the USPTO Assignment database. A copy of the ’711 Patent is attached hereto as **Exhibit 7** and incorporated herein, in its entirety, by reference.

42. The ’711 Patent is directed towards a document reading apparatus having an ADF and a flatbed scanner, or platen, on which documents can be loaded for scanning or copying. The ’711 Patent discloses improvements over prior art ADF designs by enabling a user to load documents onto both an ADF and a flatbed scanner and then sequentially scan/copy each document without manually loading or unloading documents during the scanning process. In other words, documents can be placed on the ADF and the flatbed scanner can be combined into a single document.

43. Claim 1 of the ’711 Patent is directed to at least some of these concepts and states:

A document reading apparatus, comprising:

an automatic document feeder for automatically conveying at least one document;

a first document table for holding the at least one document to be delivered to the automatic document feeder;

a first document detector for detecting the at least one document on the first document table;

a second document table on which another document is set so as to be read;

a second document detector for detecting the another document set on the second document table;

a first image reader for reading the at least one and the another documents; and

a second image reader arranged inside a document feed path of the automatic document feeder for reading an underside of the at least one document being conveyed by the automatic document feeder,

wherein when existence of the at least one and the another documents on the first and second document tables is detected from both the first and second document detectors, the at least one and the another documents set on the first and second document tables are permitted to be read.

44. Multiple Toshiba MFPs meet all limitations of Claim 1 of the '711 Patent. For example, the Toshiba MFP product model e-STUDIO2010AC is a document reading apparatus that comprises an ADF for automatically conveying at least one document:

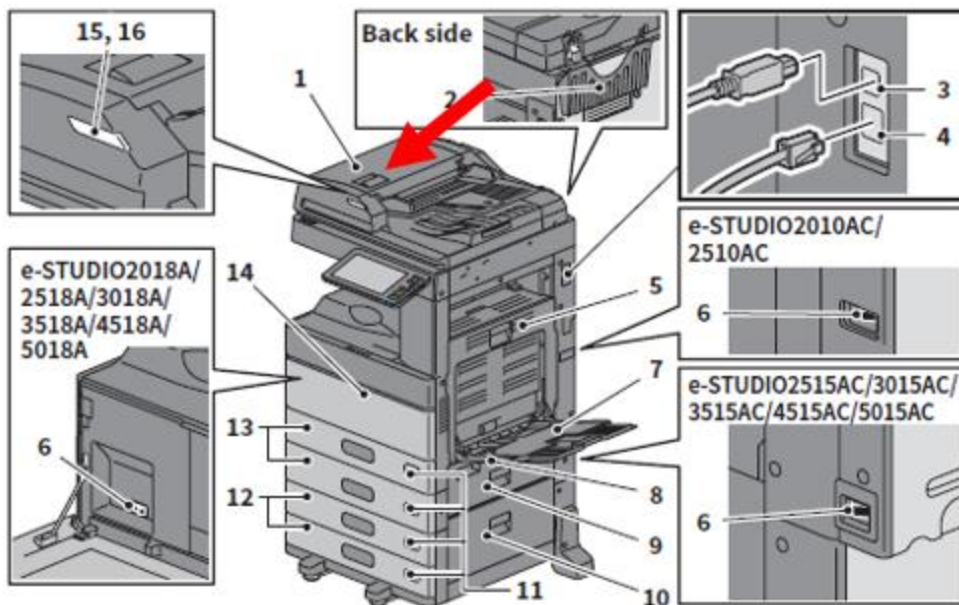

**1. Reversing Automatic Document Feeder or Dual Scan Document Feeder**  
Scans both sides of the original one sheet at a time.

45. The e-STUDIO2010AC also comprises a first document table for holding the at least one document to be delivered to the automatic document feeder and the ADF includes a paper tray for inputting documents to be scanned:



## Reversing Automatic Document Feeder / Dual Scan Document Feeder

**1**



Place the originals face up on the original feeder tray.

**2**



Align the side guides to the original length.

46. The printer also has a first document detector for detecting at least one document on the first document table, *e.g.* a detector for determining the size of the original document.

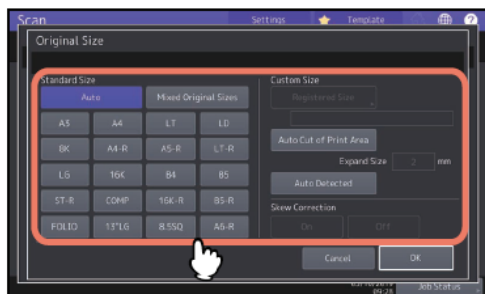

- **[Auto]**<sup>\*1</sup> – Select this option to have the equipment automatically detect the size of your originals.
- **[Mixed Original Sizes]** – Select this option when placing originals of different sizes in the ADF.
- **[Registered Size]** <sup>\*2, \*3, \*4, \*5</sup> – Select this to scan an original by a certain registered size.
- **[Auto Cut of Print Area]** <sup>\*2, \*3, \*5</sup> – Select this to clip images by automatically detecting a print area. The areas other than white are automatically detected in order to clip images.
- **[Expand Size]** – Select this to clip images while their size is made larger by a specified value than the outer circumference of the detected one, when [Auto Cut of Print Area] is chosen.
- **[Auto Detected]** <sup>\*2, \*3, \*5</sup> – Select this to clip images with the size of the original to be scanned. This function is available only when the original cover or the ADF (Automatic Document Feeder) is installed. When scanning is performed while the original cover or the ADF remains open and if fluorescent light comes in the original glass, the original size sometimes cannot be detected properly. In such a case, cover the whole of the original glass with a sheet of black paper or select the size by [Registered Size].
- **[Skew Correction]** <sup>\*6</sup> – This can be set when [Registered Size], [Auto Cut of Print Area] and [Auto Detected] are selected. Selects [On] in order to correct an image skew which has occurred during the transport of a small size original by placing it on the ADF (Auto Document Feeder). The setting of [Skew Correction] becomes [OFF] when scanning originals placed on Original glass.

\*1 This function is available only when an original is placed on the ADF to some models.

47. The e-STUDIO2010AC also comprises a second document table on which another document can be set and read and is the glass on the scanner:

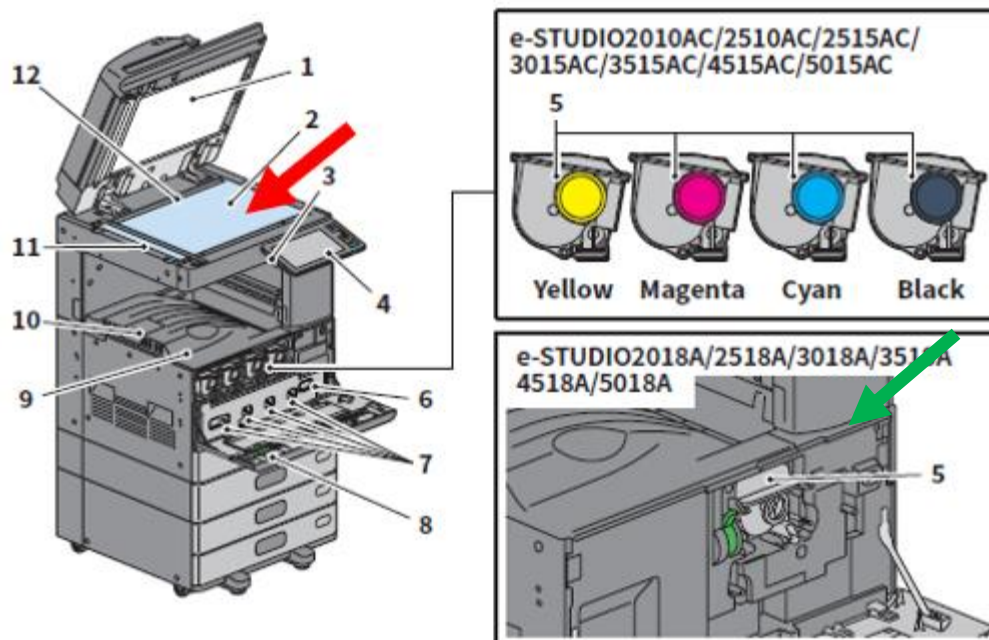



## 2. Original glass

For copying 3D originals, book-type originals, and special paper such as OHP film, as well as plain paper.

48. The e-STUDIO2010AC also has a second document detector for detecting another document set on the second document table, *e.g.* a detector for determining the size of the original document.

### Tip

- The original size is sometimes not detected correctly. To prevent this, slowly and gently close the Original Cover, Reversing Automatic Document Feeder, or Dual Scan Document Feeder.
  - You need to specify the size for the following originals because the size cannot be detected correctly.
    - Highly transparent originals (e.g. overhead transparencies, tracing paper)
    - Totally dark originals or originals with dark borders
    - Non-standard size originals (e.g. newspapers, magazines)
-  **Copying Guide** (PDF) : “Chapter 2: HOW TO MAKE COPIES” - “Specifying the Paper Size”
- When the Original Cover, the Reversing Automatic Document Feeder, or Dual Scan Document Feeder is closed, the scanner lamp flashes to detect the original size.
  - When placing mixed-size originals on the Reversing Automatic Document Feeder or Dual Scan Document Feeder, adjust the side guides to the widest original, and then align the originals against the guide on the front.
-  P.64 “FAQs”

49. The e-STUDIO2010AC also comprises a first image reader for reading documents placed on the ADF and on the scanner glass, as the below confirms:

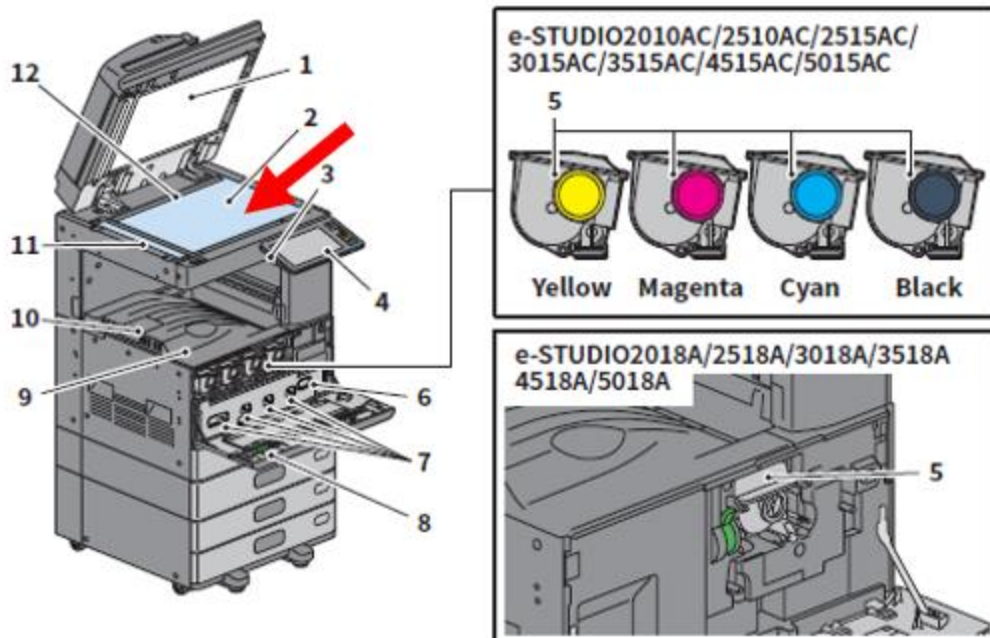

## 2. Original glass

For copying 3D originals, book-type originals, and special paper such as OHP film, as well as plain paper.

50. The e-STUDIO2010AC further has a second image reader arranged inside a document feed path of the ADF for reading an underside of the at least one document being conveyed by the ADF. The ADF includes a second image reader configured to read the opposite side of the document placed in the ADF as the document passes through the ADF, as the below also confirms:

### ■ Scanning 2-Sided originals

With the Single/2-Sided Scan setting, you can choose whether to scan your originals on both sides. Press [Scan Setting] > [Single/2-Sided Scan] and then select a surface pattern if necessary.

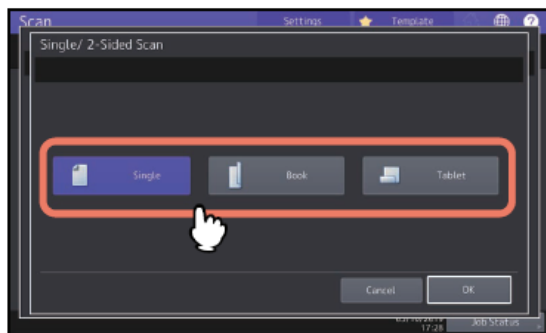

- **[Single]**— Select this option to scan only the front of the originals.
- **[Book]**— Select this option to scan both sides of the originals in the same direction.
- **[Tablet]**— Select this option to scan the front in one direction and the back rotated by 180 degrees.

51. When the existence of documents on the first and second document tables is detected by both the first and second document detectors, the at least one and other documents set on the first and second document tables are permitted to be read. When original documents are placed in both the ADF tray and on the platen, the Accused Device scans the documents in the ADF tray in response to a scan command. Once the ADF tray is empty, a further scan command causes the Accused Device to scan the documents on the platen. All scanned documents can be combined into a single output document.

**Scanning the next original**

When the original is set on the glass or [Continue] is pressed during scanning on the ADF, the confirmation screen for the next original will be displayed. In either case, when you set the next original and press [Scan], it will be scanned. Follow this procedure as many times as necessary. When all of the scanning is finished, press [Job Finish].

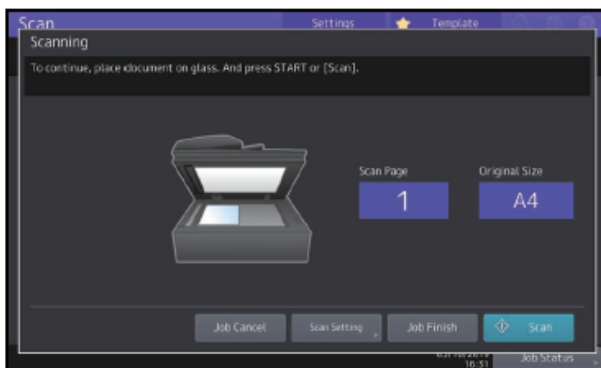

- To cancel the operation, press [Job Cancel].
- To change the scan settings, press [Scan Setting].

P.38 “Changing Scan Settings”

## 5. U.S. Patent 10,018,938

52. On July 10, 2018, the USPTO duly and legally issued U.S. Patent No. 10,018,938 (“the ’938 Patent”) entitled “Network System Comprising Customer Replaceable Unit” to Sharp. Sharp assigned the ’938 Patent to K.Mizra and that Assignment is recorded beginning at Reel/Frame No. 054223/0499 of the USPTO Assignment database. A copy of the ’938 Patent is attached hereto as **Exhibit 9** and incorporated herein, in its entirety, by reference.

53. The ’938 Patent is directed to a server connected to a networked multifunction printer having a consumable replaceable unit, such as a toner cartridge. When the server obtains operation information from the printer, it can determine the remaining level of toner in the printer, and can send toner reorder information when the remaining toner reaches a set threshold.

54. Claim 3 of the '938 Patent is directed to at least some of these concepts and states:

A system comprising:

an accumulation portion configured to accumulate an operation performance for calculating an amount of remaining toner held in a toner supply container of a developing device attached to an image forming apparatus;

a calculation portion configured to calculate the amount of remaining toner held in the toner supply container based on the operation performance accumulated by the accumulation portion;

a determination portion configured to determine whether the amount of remaining toner reaches a threshold; and

a sending portion configured to send order information when it is determined that the amount of remaining toner reaches the threshold.

55. Toshiba's servers in combination with compatible Toshiba MFPs meet all limitations of Claim 1 of the '938 Patent. For example, Toshiba's Encompass Managed Print Services ("EMPS") service allows Toshiba to monitor its customers' supplies of toner in their Toshiba MFPs and automatically initiate replenishment orders, as shown below:



**Leveraging Toshiba's PageSmart Program, you get toner, service, parts and labor included in one low, cost-per-page price through one reliable service provider.**



**Toshiba's PageSmart program includes:**

- > Automated toner replenishment services
- > High quality toner and parts for your laser printers
- > National on-site service
- > Convenient online portal for service requests and reporting
- > Proactive service monitoring

56. To enable EMPS, the Toshiba e-BRIDGE Fleet Management System collects information from Toshiba's MFPs about device usage and supplies and exchanges such information over a network with Toshiba's data warehouse:

## e-BRIDGE Fleet Management System

e-BRIDGE Fleet Management System allows you to instantly gather information from networked Toshiba multifunction systems throughout your company. e-BRIDGE Fleet Management System

- Monitor meter readings, machine availability, toner, and paper supply status.
- Define grouped devices by model, cost center, department, or location.
- Customize reports, covering groups of devices which can be defined as templates

57. Each Toshiba e-STUDIO MFP is an image forming device that, using toner, executes print jobs through an image forming apparatus and has a controller board that manages internal operations. Recording toner usage through the device's sensor and control, the e-STUDIO MFP collects and reports up-to-date metrics and

page counts to the e-BRIDGE Fleet Management System as the information accumulates. The e-BRIDGE Fleet Management System receives data about the e-STUDIO MFP's operation and calculates the amount of remaining toner supply. The e-BRIDGE Fleet Management System is then able to determine when the amount of remaining toner reaches a threshold at which resupply will become necessary:

### Fleet Monitoring

Using Toshiba's intelligent fleet monitoring system, which tracks all networked devices and desktop laser printers, you can see detailed user information and receive appropriate service alert notifications such as low or no toner, preventive maintenance required and mechanical failure.

58. When a device's supply level reaches that threshold, it triggers the e-BRIDGE Fleet Management System to submit a replenishment order to Toshiba. The technology necessary for Toshiba's EMPS service to occur – the accumulation and calculation of usage data, and the server's ability to initiate the proper workflow in response to this data – is disclosed in and claimed by at least Claim 3 of the '938 Patent.

59. The claims of the '938 Patent are not directed to an abstract idea. Rather, the '938 Patent presents a technical solution to a hardware problem. The '938 Patent is directed to previously existing problems with toner cartridges used in MFPs. The hardware environment relevant to the '938 Patent includes several physical components, as illustrated in Figure 5 from the patent:

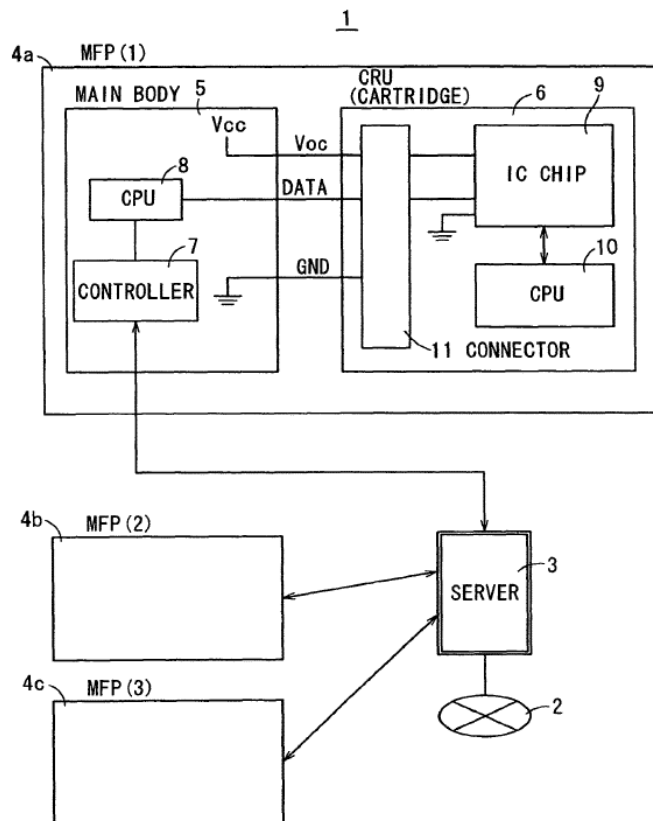
*FIG. 5 PRIOR ART*

These include one or more MFPs having one or more toner cartridges, identified as “CRUs” (customer replaceable units). The CRUs are electronic devices that include CPUs and IC chips that are in communication with the main body of an MFP, which in turn is connected to a server. The logic within the CRU is stored on a CRU memory, referred to as a “CRUM.” **Exhibit 9** (’938 Patent) at 1:29-32

60. The ’938 Patent is directed toward improvements in the performance and security of the system depicted in Figure 5. In particular, the ’938 Patent recognizes the limitations of prior art approaches for “stor[ing] information on ordering into a CRUM in advance and, when a CRU reaches the limits of use through operation,

provid[ing] the order information” to a user, as well as “stor[ing] a software code upgrade into a CRUM in advance so that the operator can update a software code without the need for calling a field engineer or the like.” *Id.* at 2:19-32. Letting the prior art CRUM store the information created a security risk that counterfeit products could be manufactured by analyzing and reproducing the information stored in the prior art CRUM. *Id.* at 2:34-41. The ’938 Patent also recognized that memory storage limits on local CRUMs may create difficulties in storing large amounts of information. *Id.* at 2:41-45

61. The solution to these problems, as described and claimed by the ’938 Patent, involves migrating the functions of the CRUM to a remote server, thereby enhancing the operational efficiency and security of the network. As the ’938 Patent explains:

An object of the invention is to provide a network system comprising a customer replaceable unit having an excellent security function for operation information which system can realize improvement of the use efficiency of operation information for making a customer replaceable unit operate and reduction in costs.

*Id.* at 8:30-36. The ’938 Patent goes on to explain how the server performs the function of calculating when a CRU should be replaced. For example, the specification states:

In the server 22, the amount of remaining toner held in the toner supply container is calculated from the accumulated operation performance, namely, the number of rotations of the toner supply roller, and it is determined whether the operation performance has reached the first and second threshold values or not.

*Id.* at 8:30-36. The patent’s specification also highlights how this improves the security of the system and the operation of the CRUM:

According to the invention, in response to the detection result of the end of communication between the main-body communicating portion and the unit communicating portion 45 by the communication end detecting portion, that is, when an operation of the apparatus main body and the customer replaceable unit based on information communication ends, the operation information of the customer replaceable unit stored in the main-body storing portion is erased by the information erasing means. Consequently, the operation information necessary for the operation of the customer replaceable unit does not remain in either the apparatus main body or the customer replaceable unit, but remains only in the server. Therefore, it is possible to prevent information leakage, and exhibit a high security function.

*Id.* at 3:43-56. In other words, because operational information is maintained only in a remote server, the risk of improperly accessing and using the information previously housed on a remote CRUM, *e.g.*, to manufacture counterfeit products, is minimized.

62. In sum, the '938 Patent describes a technical solution (calculation and storage of information at a server rather than a local device) to a hardware problem (securely and efficiently maintaining appropriate toner levels in an MFP). Accordingly, the '938 Patent is not directed to an abstract idea.

63. The claims of the '938 Patent also contain an inventive concept and thus the claimed invention is not well-known, routine or conventional. The claims of the '938 Patent do not recite generic components, but rather non-generic features such as an image forming apparatus containing a CRU, neither of which are components of a generic computer. The claims of the '938 Patent are tied to specific machines – MFPs containing CRUs – and are thus not properly considered generic.

64. Indeed, the USPTO acknowledged the eligibility of the claimed invention of the '938 Patent. During prosecution of U.S. Patent Application No.

11/506,082 (“the ‘082 Application”), the parent application of the ’938 Patent, the Examiner ultimately determined that claims including the main body, CRU, server, and network were ineligible under 35 U.S.C. § 101 (“Section 101”). The file history of the ‘082 Application is attached and incorporated herein as **Exhibit 11**. *See Exhibit 11* (‘082 App.), 3/4/2016 OA at 4-18. The Examiner initially asserted that the invention was “directed to an abstract idea including a method of organizing human activities using a generic computer without reciting significantly more than the abstract idea.” *Id.*, 6/3/2016 Amendment at 9. In response, the Applicant explained why the Examiner’s conclusion was incorrect.

65. First, the Applicant stated that the claimed invention includes “a server, an imaging forming apparatus, and a customer replaceable unit (CRU),” and thus is “unequivocally not a method of organizing human activities.” *Id.* The Applicant also refuted the Examiner’s assertion that the invention was mere “data gathering,” explaining that this improperly described the invention “at a high level of abstraction while ignoring [claimed] limitation[s].” *Id.* Rather, the Applicant explained that the “recited network system, method, and apparatus include an image forming apparatus containing a customer replaceable unit (CRU), neither of which are components of a generic computer.” *Id.* The Applicant then referenced the specification’s description of “the unique advantages and benefits achieved by Applicant’s claimed invention.”

*Id.* at 9-10. In response, the Examiner deemed the Applicant's arguments "persuasive" and withdrew the rejection under Section 101. *Id.*, 9/1/2006 OA at 26.<sup>1</sup>

66. Although the claims of the '938 Patent are different from the claims at issue in the parent application, they nonetheless recite a "server" and an "image forming apparatus" as in the '082 Application, as well as the critical CRU. The specifications are also the same. Thus, the Applicant's arguments from the '082 Application, and the Examiner's conclusion as to Section 101 eligibility, apply with equal force to the '938 Patent.

**6. U.S. Patent No. 7,840,165**

67. On November 23, 2010, the USPTO duly and legally issued U.S. Patent No. 7,840,165 ("the '165 Patent") entitled "Toner Replenishing Apparatus, Image Forming Apparatus, and Color Image Forming Apparatus" to Sharp. Sharp assigned the '165 Patent to K.Mizra and that Assignment is recorded beginning at Reel/Frame No. 054223/0499 of the USPTO Assignment database. A copy of the '165 Patent is attached hereto as **Exhibit 12** and incorporated herein, in its entirety, by reference.

68. The '165 Patent is directed to a server connected to a toner replenishing apparatus that allows easy removal of toner replenishing containers. The claimed device includes displacement mechanisms that allow toner replenishing containers to be displaced from operative positions for removal and replacement.

69. Claim 9 of the '165 Patent is directed to at least some of these concepts

---

<sup>1</sup> The Examiner maintained additional grounds of rejection and the '082 Application was abandoned.

and states:

A color image forming apparatus comprising:

a plurality of image bearing members on each of which is to be formed a latent image;

a plurality of latent-image forming sections each for forming a latent image on the image bearing member;

a plurality of developing devices each for developing the latent image formed on the image bearing member with use of toner, the toners used for the respective developing devices being of different colors from each other;

a plurality of toner replenishing containers each for accommodating toner to be replenished to a developing device corresponding thereto;

a container holding member for holding the plurality of toner replenishing containers in a detachable manner;

and

a plurality of displacement mechanisms each for displacing the corresponding toner replenishing container from a position where the corresponding toner replenishing container is held by the container holding member; and

a plurality of shutter sections for opening and closing toner replenishing ports which are formed in the toner replenishing containers for replenishing toner to the developing device,

wherein the shutter sections bring the toner replenishing ports into a closed state in conjunction with the displacement of the toner replenishing containers by the displacement mechanisms.

70. The Toshiba MFP product model e-STUDIO389CS is a color image forming apparatus.



**e-STUDIO389CS**

**40 PPM Color A4-Size MFP**

Copy, Print, Scan & Fax - Standard  
650/2,300 Paper Capacity (Std./Max)  
Compact Design  
Customizable Workflow  
Available in U.S. and Latin America



71. The e-STUDIO389CS comprises a plurality of image bearing members on each of which is to be formed a latent image, as well as a plurality of developing devices each for developing the latent image formed on the image bearing member with use of toner, the toners used for the respective developing devices being of different colors from each other:

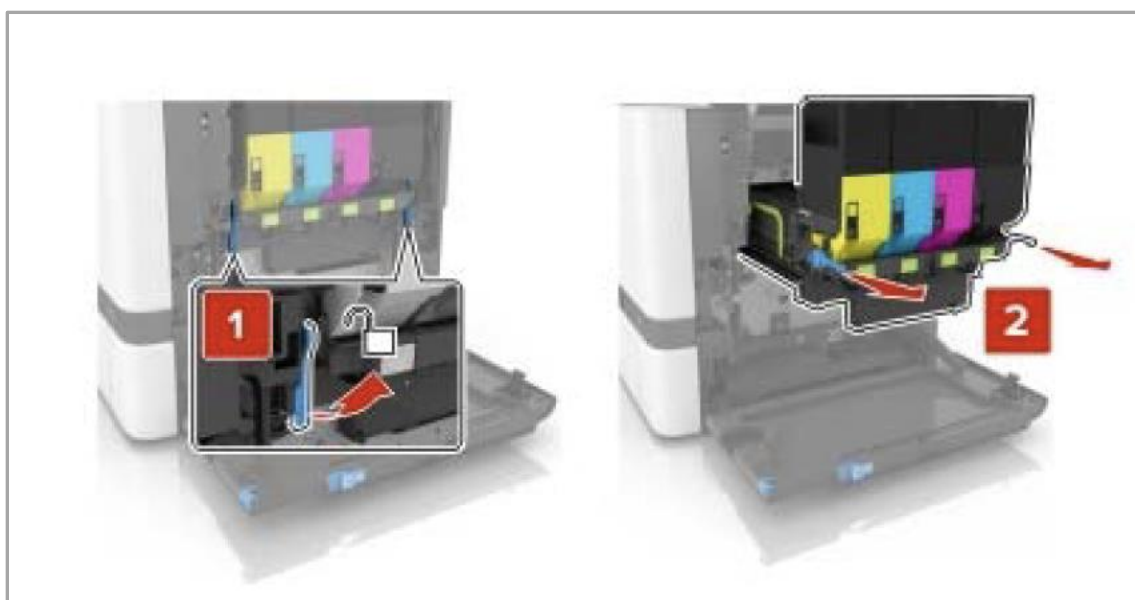
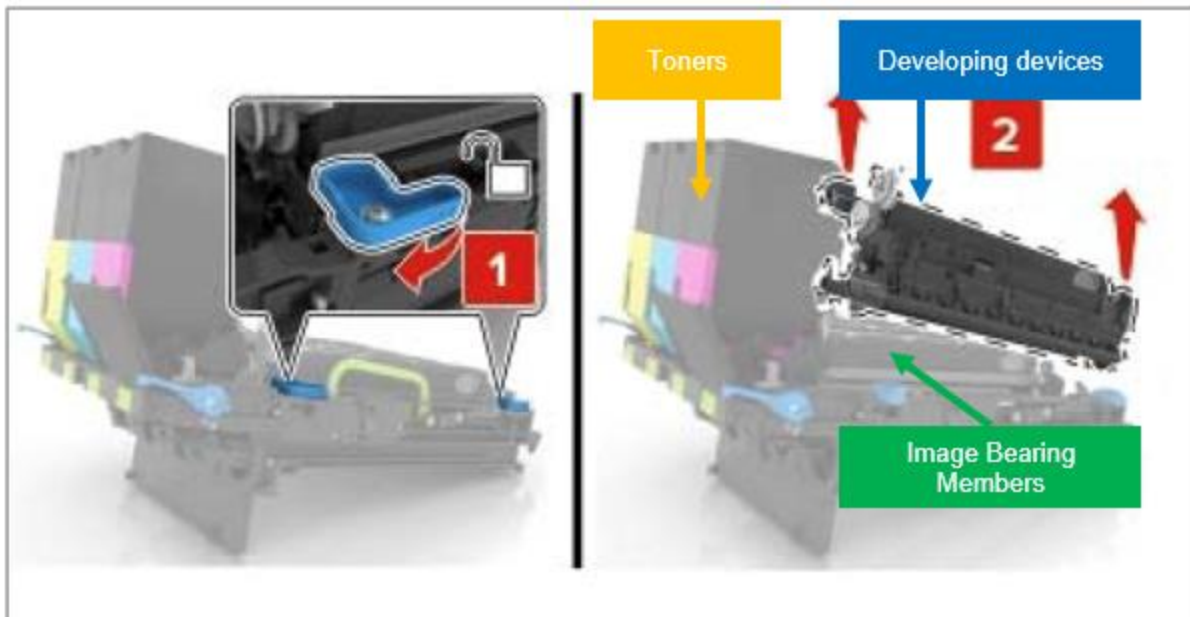

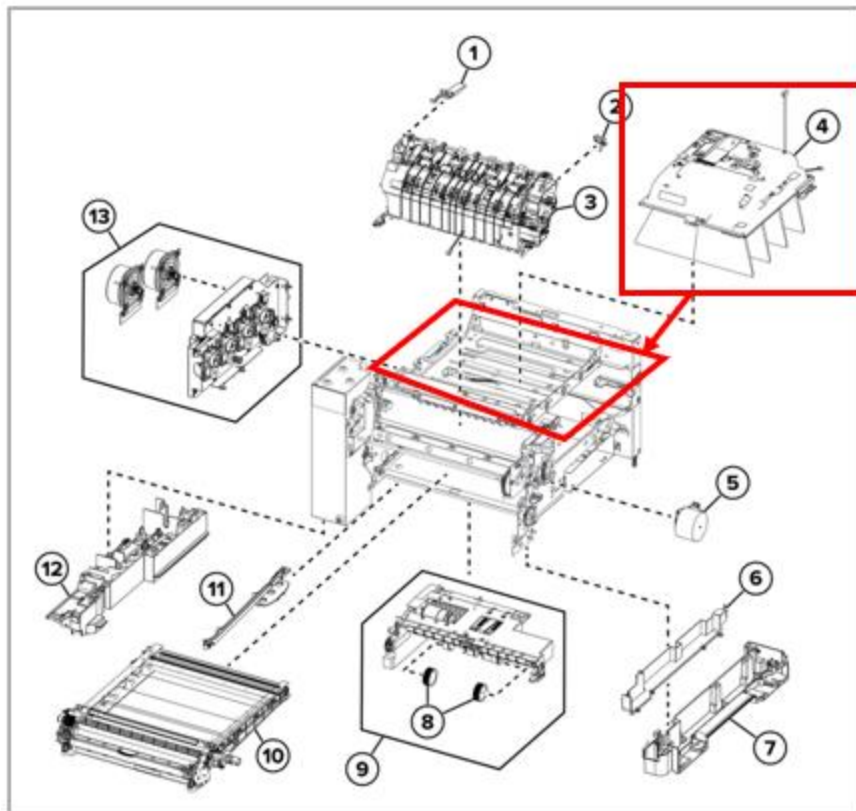

72. The e-STUDIO389CS comprises a plurality of latent-image forming sections each for forming a latent image on the image bearing member:









73. The e-STUDIO389CS comprises a plurality of toner replenishing containers each for accommodating toner to be replenished to a developing device corresponding thereto:

**Toshiba e-STUDIO 389CS Black Toner Cartridges**

|  |   |                           |                |   |   |
|--|---|---------------------------|----------------|---|---|
| <br>Leading Innovation >> | ITEM TFC389UKR<br>Toshiba TFC389UKR Black Toner Cartridge<br>TFC389UKR Black Toner Cartridge; Yield: 20,000 pages | Status<br><b>In Stock</b> | <b>\$72.99</b> | 1 |  |
|--|---|---------------------------|----------------|---|---|

**Toshiba e-STUDIO 389CS Color Toner Cartridges**

|  |   |  |                 |   |   |
|--|---|--|-----------------|---|---|
| <br>Leading Innovation >> | ITEM TFC389UCR<br>Toshiba TFC389UCR Cyan Toner Cartridge<br>TFC389UCR Cyan Toner Cartridge; Yield: 13,000 pages       | Status<br><b>In Stock</b><br>Free Shipping | <b>\$178.99</b> | 1 |  |
| <br>Leading Innovation >> | ITEM TFC389UMR<br>Toshiba TFC389UMR Magenta Toner Cartridge<br>TFC389UMR Magenta Toner Cartridge; Yield: 13,000 pages | Status<br><b>In Stock</b><br>Free Shipping | <b>\$178.99</b> | 1 |  |
| <br>Leading Innovation >> | ITEM TFC389UYR<br>Toshiba TFC389UYR Yellow Toner Cartridge<br>TFC389UYR Yellow Toner Cartridge; Yield: 13,000 pages   | Status<br><b>In Stock</b><br>Free Shipping | <b>\$178.99</b> | 1 |  |

74. The e-STUDIO389CS comprises a container holding member for holding the plurality of toner replenishing containers in a detachable manner, and a plurality of displacement mechanisms each for displacing the corresponding toner replenishing container from a position where the corresponding toner replenishing container is held by the container holding member:

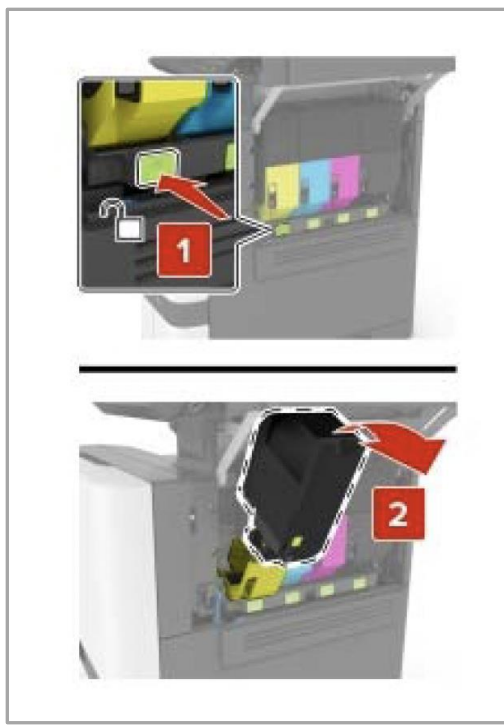

75. The e-STUDIO389CS comprises a plurality of shutter sections for opening and closing toner replenishing ports which are formed in the toner replenishing containers for replenishing toner to the developing device, wherein the shutter sections bring the toner replenishing ports into a closed state in conjunction with the displacement of the toner replenishing containers by the displacement mechanisms:

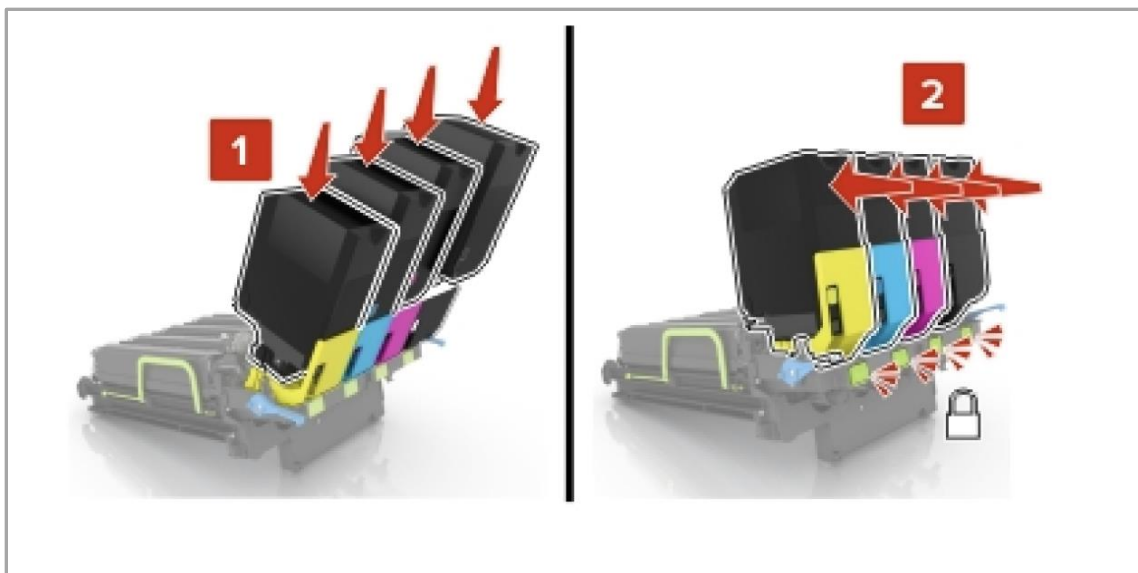

## **V. TOSHIBA'S KNOWLEDGE OF THE ASSERTED PATENTS**

76. Toshiba previously entered into a patent license agreement with Sharp which has since expired. On information and belief, at least as a result of that license agreement, Toshiba has had actual knowledge of the Asserted Patents and, as of the expiration of that license agreement, Toshiba has had actual knowledge of its infringement of the Asserted Patents.

## **VI. FIRST CLAIM FOR RELIEF** **(Count I – Patent Infringement of U.S. Patent No. 7,064,874)** **(Against all Defendants)**

77. Plaintiff repeats and re-alleges the allegations above in Paragraphs 1 – 28 and 76 as if fully set forth herein.

78. The '874 Patent includes 18 claims. Toshiba directly infringes and has infringed one or more of these claims without authority of Plaintiff by importing, manufacturing, using, offering for sale, and selling products and systems.

79. More specifically and without limitation, Toshiba has been and is directly infringing, either literally or under the doctrine of equivalents, at least Claim 18 of the '874 Patent by importing, manufacturing, using, offering for sale, and selling infringing MFPS, including but not limited to the e-STUDIO5506AC as shown in the '874 Patent Preliminary Claim Chart, attached as **Exhibit 2** and incorporated herein by reference, and the additional Toshiba '874 Patent Accused Products.

80. ABS has infringed the '874 patent by selling and offering for sale Toshiba products that infringe the '874 Patent, including but not limited to the e-STUDIO5506AC.

81. Clearview has infringed the '874 patent by selling and offering for sale Toshiba products that infringe the '874 patent, including but not limited to the e-STUDIO400AC.

82. Copy Concepts has infringed the '874 patent by selling and offering for sale Toshiba products that infringe the '874 patent, including but not limited to the e-STUDIO3015AC.

83. Toshiba and ABS are thus liable for direct infringement of the '874 Patent pursuant to 35 U.S.C. § 271(a).

84. On information and belief, Toshiba's infringement of the '874 Patent has been and continues to be willful.

85. Toshiba and ABS are liable to Plaintiff in an amount that adequately compensates it for their infringement in an amount that is not less than a reasonable royalty, together with interest and costs as fixed by this Court under 35 U.S.C. § 284.

86. Plaintiff has been damaged and will suffer additional damages and irreparable harm unless Toshiba and ABS are enjoined from further infringement under 35 U.S.C. § 283.

**VII. SECOND CLAIM FOR RELIEF**  
**(Count II – Patent Infringement of U.S. Patent No. 7,570,400)**  
**(Against all Defendants)**

87. Plaintiff repeats and re-alleges the allegations above in Paragraphs 1 – 21, 29 – 35 and 76 as if fully set forth herein.

88. The '400 Patent includes 4 claims. Toshiba directly infringes one or more of these claims without authority of Plaintiff by importing, manufacturing, using, offering for sale, and selling products and systems.

89. More specifically and without limitation, Toshiba has been and is directly infringing, either literally or under the doctrine of equivalents, at least Claim 1 of the '400 Patent by importing, manufacturing, using, offering for sale, and selling infringing MFPS, including but not limited to the e-STUDIO5518A as shown in the '400 Patent Preliminary Claim Chart, attached as **Exhibit 4** and incorporated herein by reference, and the additional Toshiba '400 Patent Accused Products.

90. The Dealer Defendants have infringed the '400 patent by selling and offering for sale Toshiba products that infringe the '400 Patent, including but not limited to the e-STUDIO5518A.

91. All Defendants are thus liable for direct infringement of the '400 Patent pursuant to 35 U.S.C. § 271(a).



92. On information and belief, Toshiba's infringement of the '400 Patent has been and continues to be willful.

93. All Defendants are liable to Plaintiff in an amount that adequately compensates it for their infringement in an amount that is not less than a reasonable royalty, together with interest and costs as fixed by this Court under 35 U.S.C. § 284.

94. Plaintiff has been damaged and will suffer additional damages and irreparable harm unless Defendants are enjoined from further infringement under 35 U.S.C. § 283.

**VIII. THIRD CLAIM FOR RELIEF**  
**(Count III – Patent Infringement of U.S. Patent No. 7,852,504)**  
**(Against Toshiba and Clearview)**

95. Plaintiff repeats and re-alleges the allegations above in Paragraphs 1 – 21, 36 – 40 and 76 as if fully set forth herein.

96. The '504 Patent includes 21 claims. Toshiba directly infringes one or more of these claims without authority of Plaintiff by importing, manufacturing, using, offering for sale, and selling products and systems.

97. More specifically and without limitation, Toshiba has been and is directly infringing, either literally or under the doctrine of equivalents, at least Claim 1 of the '504 Patent by importing, manufacturing, using, offering for sale, and selling infringing MFPs, including but not limited to the e-STUDIO907 as shown in the '504 Patent Preliminary Claim Chart, attached as **Exhibit 6** and incorporated herein by reference, and the additional Toshiba '504 Patent Accused Products.

98. Clearview has infringed the '504 patent by selling and offering for sale Toshiba products that infringe the '504 Patent, including but not limited to the e-STUDIO907.

99. Toshiba and Clearview are thus liable for direct infringement of the '504 Patent pursuant to 35 U.S.C. § 271(a).

100. On information and belief, Toshiba's infringement of the '504 Patent has been and continues to be willful

101. Toshiba and Clearview are liable to Plaintiff in an amount that adequately compensates it for their infringement in an amount that is not less than a reasonable royalty, together with interest and costs as fixed by this Court under 35 U.S.C. § 284.

102. Plaintiff has been damaged and will suffer additional damages and irreparable harm unless Toshiba and Clearview are enjoined from further infringement under 35 U.S.C. § 283.

**IX. FOURTH CLAIM FOR RELIEF**  
**(Count IV – Patent Infringement of U.S. Patent No. 8,274,711)**  
**(Against Toshiba, Clearview and Copy Concepts)**

103. Plaintiff repeats and re-alleges the allegations above in Paragraphs 1 – 21, 41 – 51 and 76 as if fully set forth herein.

104. The '711 Patent includes 12 claims. Toshiba directly infringes one or more of these claims without authority of Plaintiff by importing, manufacturing, using, offering for sale, and selling products and systems.

105. More specifically and without limitation, Toshiba has been and is directly infringing, either literally or under the doctrine of equivalents, at least Claim 1 of the '711 Patent by importing, manufacturing, using, offering for sale, and selling infringing MFPS, including but not limited to the e-STUDIO2010AC as shown in the '711 Patent Preliminary Claim Chart, attached as **Exhibit 8** and incorporated herein by reference.

106. Clearview and Copy Concepts have infringed the '711 patent by selling and offering for sale Toshiba products that infringe the '711 Patent, including but not limited to the e-STUDIO2010AC.

107. Toshiba, Clearview and Copy Concepts are thus liable for direct infringement of the '711 Patent pursuant to 35 U.S.C. § 271(a).

108. On information and belief, Toshiba's infringement of the '711 Patent has been and continues to be willful

109. Toshiba, Clearview and Copy Concepts are liable to Plaintiff in an amount that adequately compensates it for their infringement in an amount that is not less than a reasonable royalty, together with interest and costs as fixed by this Court under 35 U.S.C. § 284.

110. Plaintiff has been damaged and will suffer additional damages and irreparable harm unless Toshiba, Clearview and Copy Concepts are enjoined from further infringement under 35 U.S.C. § 283.

**X. FIFTH CLAIM FOR RELIEF**  
**(Count V – Patent Infringement of U.S. Patent No. 10,018,938)**  
**(Against Toshiba)**

111. Plaintiff repeats and re-alleges the allegations above in Paragraphs 1 – 21, 52 – 66 and 76 as if fully set forth herein.

112. The '938 Patent includes 4 claims. Toshiba directly infringes one or more of these claims without authority of Plaintiff by importing, manufacturing, using, offering for sale, and selling products and systems.

113. More specifically and without limitation, Toshiba has been and is directly infringing, either literally or under the doctrine of equivalents, at least Claim 3 of the '938 Patent by importing, manufacturing, using, offering for sale, and selling infringing services and compatible MFPs, including but not limited to the Encompass Managed Print Services and compatible e-STUDIO MFPs as shown in the '938 Patent Preliminary Claim Chart, attached as **Exhibit 10** and incorporated herein by reference.

114. Toshiba is thus liable for direct infringement of the '938 Patent pursuant to 35 U.S.C. § 271(a).

115. On information and belief, Toshiba's infringement of the '938 Patent has been and continues to be willful

116. Toshiba is liable to Plaintiff in an amount that adequately compensates it for Toshiba's infringement in an amount that is not less than a reasonable royalty, together with interest and costs as fixed by this Court under 35 U.S.C. § 284.

117. Plaintiff has been damaged and will suffer additional damages and irreparable harm unless Toshiba is enjoined from further infringement under 35 U.S.C. § 283.

**XI. SIXTH CLAIM FOR RELIEF**  
**(Count VI – Patent Infringement of U.S. Patent No. 7,840,165)**  
**(Against Toshiba, ABS and Clearview)**

118. Plaintiff repeats and re-alleges the allegations above in Paragraphs 1 – 21 and 67 –76 as if fully set forth herein.

119. The '165 Patent includes 9 claims. Toshiba directly infringes one or more of these claims without authority of Plaintiff by importing, manufacturing, using, offering for sale, and selling products and systems.

120. More specifically and without limitation, Toshiba has been and is directly infringing, either literally or under the doctrine of equivalents, at least Claim 9 of the '165 Patent by importing, manufacturing, using, offering for sale, and selling infringing MFPs, including but not limited to the e-STUDIO389CS as shown in the '165 Patent Preliminary Claim Chart, attached as **Exhibit 13** and incorporated herein by reference.

121. ABS and Clearview have infringed the '165 patent by selling and offering for sale Toshiba products that infringe the '165 Patent, including but not limited to the e-STUDIO389CS.

122. Toshiba, ABS and Clearview are thus liable for direct infringement of the '165 Patent pursuant to 35 U.S.C. § 271(a).

123. On information and belief, Toshiba's infringement of the '165 Patent has been and continues to be willful.

124. Toshiba, ABS and Clearview are liable to Plaintiff in an amount that adequately compensates it for their infringement in an amount that is not less than a reasonable royalty, together with interest and costs as fixed by this Court under 35 U.S.C. § 284.

125. Plaintiff has been damaged and will suffer additional damages and irreparable harm unless Defendants are enjoined from further infringement under 35 U.S.C. § 283.

## **XII. PRAYER FOR RELIEF**

K.Mizra requests that the Court find in its favor and against Defendants, and that the Court grant K.Mizra the following relief:

- A. Judgment that one or more claims of the Asserted Patents have been infringed, either literally and/or under the doctrine of equivalents, by Defendants;
- B. Declaring that the Asserted Patents are valid and enforceable;
- C. Ordering that Defendants, their officers, directors, agents, servants, employees, privies, representatives, attorneys, parent and subsidiary corporations or other related entities, successors, assigns, licensees, retail distributors, and all persons in active concert or participation with any of them, be preliminary and permanently enjoined from further acts of infringement of the Asserted Patents;
- D. Awarding damages in an amount to be proven at trial, but in no event less than a reasonable royalty, for Defendants' infringement;

E. Judgment that Defendants account for and pay to K.Mizra all damages to, including a reasonable royalty, and costs incurred by K.Mizra because of Defendants' infringing activities and other conduct complained of herein, including an award of all increased damages to which K.Mizra is entitled under 35 U.S.C. § 284;

F. Declaring this an exceptional case and awarding K.Mizra its attorneys' fees and costs in accordance with 35 U.S.C. § 285;

G. Pre-judgment and post-judgment interest on the damages caused to K.Mizra by reason of Defendants' infringing activities and other conduct complained of herein; and

H. Such other and further relief as the Court may deem just and proper under the circumstances.

**XIII. DEMAND FOR JURY TRIAL**

K.Mizra requests a trial by jury pursuant to Fed. R. Civ. P. 38.

Dated: August 12, 2021.

Respectfully submitted,

/s/ Thomas A. Zehnder

Thomas A. Zehnder

Florida Bar No. 0063274

Robyn M. Kramer

Florida Bar No.: 0118300

KING, BLACKWELL, ZEHNDER & WERMUTH, P.A.

25 E. Pine Street

P.O. Box 1631

Orlando, FL 32802-1631

Telephone: (407) 422-2472

Facsimile: (407) 648-0161

tzehnder@kbzwlaw.com

rkramer@kbzwlaw.com

Robert R. Brunelli\*  
Patricia Y. Ho\*  
Matthew C. Holohan\*  
Paul Sung Cha\*  
SHERIDAN ROSS P.C.  
1560 Broadway, Suite 1200  
Denver, CO 80202  
Telephone: (303) 863-9700  
Facsimile: (303) 863-0223  
rbrunelli@sheridanross.com  
pho@sheridanross.com  
mholohan@sheridanross.com  
pscha@sheridanross.com  
litigation@sheridanross.com

*\*(Motions to appear pro hac vice forthcoming)*

*Counsel for Plaintiff K.Mizra LLC*